

# CINTEC INTERNATIONAL

Keyhole surgery for buildings and structures



Structural repair solutions for stabilisation and conservation

# The Cintec Anchor System

The Cintec Anchor System is a versatile method of structural reinforcement that can be tailored to meet specific strengthening and repair requirements.

From historic buildings and monuments to bridges, high-rise blocks and harbour walls, Cintec has established a worldwide and highly respected reputation for resolving the technical challenges of structural preservation, while remaining sensitive to the original architecture.

The Cintec System comprises a steel section in a mesh fabric sleeve into which a specially developed cementitious grout is injected under low pressure. The flexible sleeve of woven polyester restrains the flow and moulds the anchor into the shapes and spaces within the walls, providing a strong mechanical yet sympathetic bond.

The large surface area of the expanded anchor creates a reinforcement system that dispenses with the need for unsightly patress plates on the exterior of the structure, providing an invisible mend.

## The Grout

Especially developed by Cintec, Presstec is a cementitious grout with graded aggregates and other constituents which when mixed with water produces a pumpable grout of proven strength and no shrinkage.

## The Sock

The fabric sleeve is a specially woven polyester-based tubular sock with expansion properties to suit the diameter of the bore hole and particular substrate.

## The Reinforcing Member

The choice of reinforcing members depends largely on the anticipated loads and the life expectancy of the anchor.

## The Parent Material

The strength of the parent material and/or mortar can govern the anchor capacity. Where the parent material or mortar strength is indeterminable, the capacity of the material/mortar can be accurately determined from insitu anchor tests.

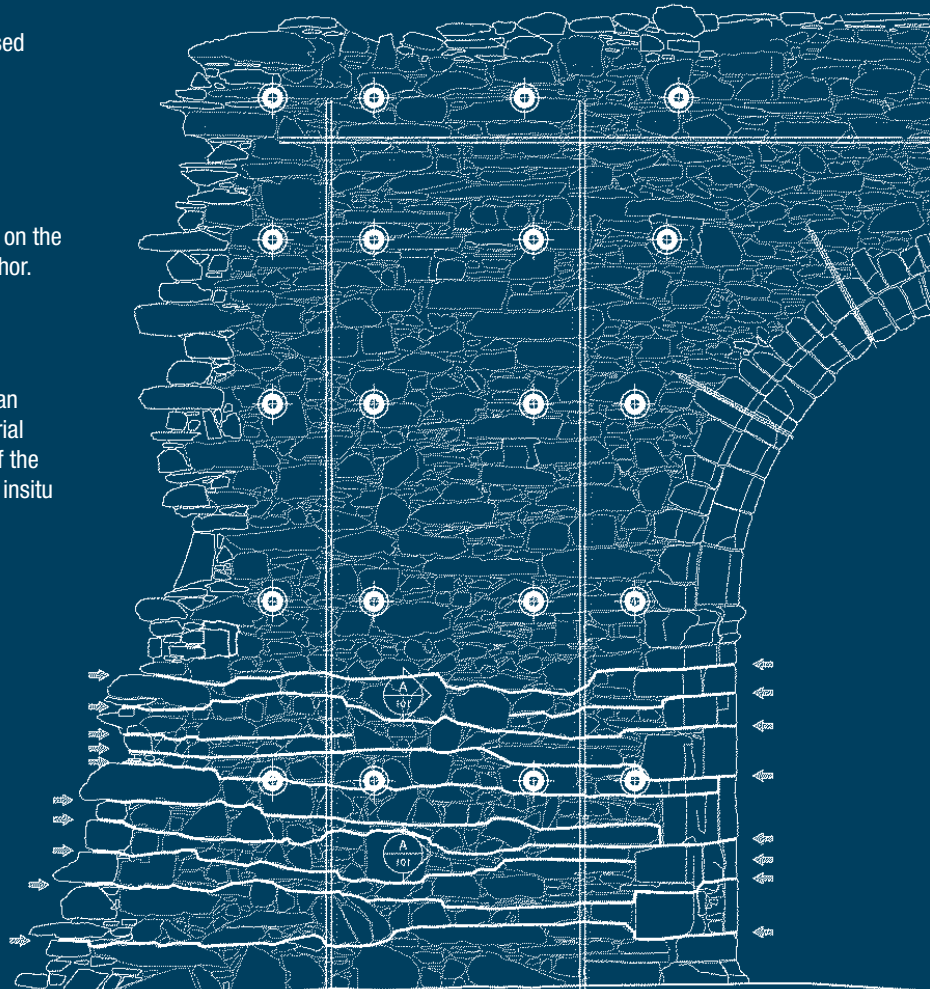
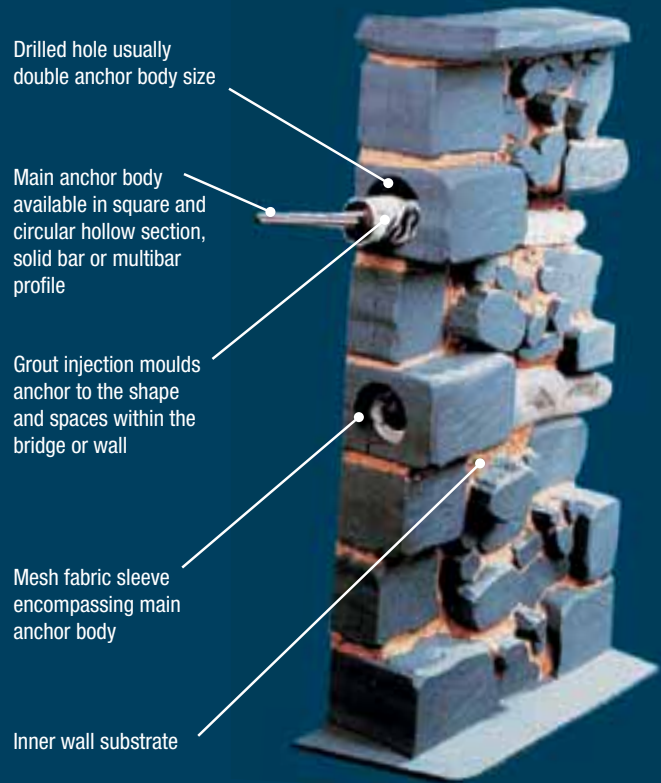

Typical cross section of how our anchor system is used. Cymer Abbey Dollgellau, Wales.



## Lateral Restraint

**Problem:** External walls separating from main structure, lack of lateral restraint.

**Solution:** Cintec stitching anchors through external wall into internal wall, lateral restraint anchors through external wall and through floor joists, "Armlock" adjustable restraint device attached to joists and fixed by Cintec stud anchor fixed into wall.

At roof level, "Gablelock" fixed over top of ceiling joists and to external wall with Cintec stud anchors.

**Problem:** Subsidence or settlement of foundations causing wall to move or rotate.

**Solution:** Cintec stitching anchors in "overpinning" to transfer load back over firm foundation away from failing foundation.

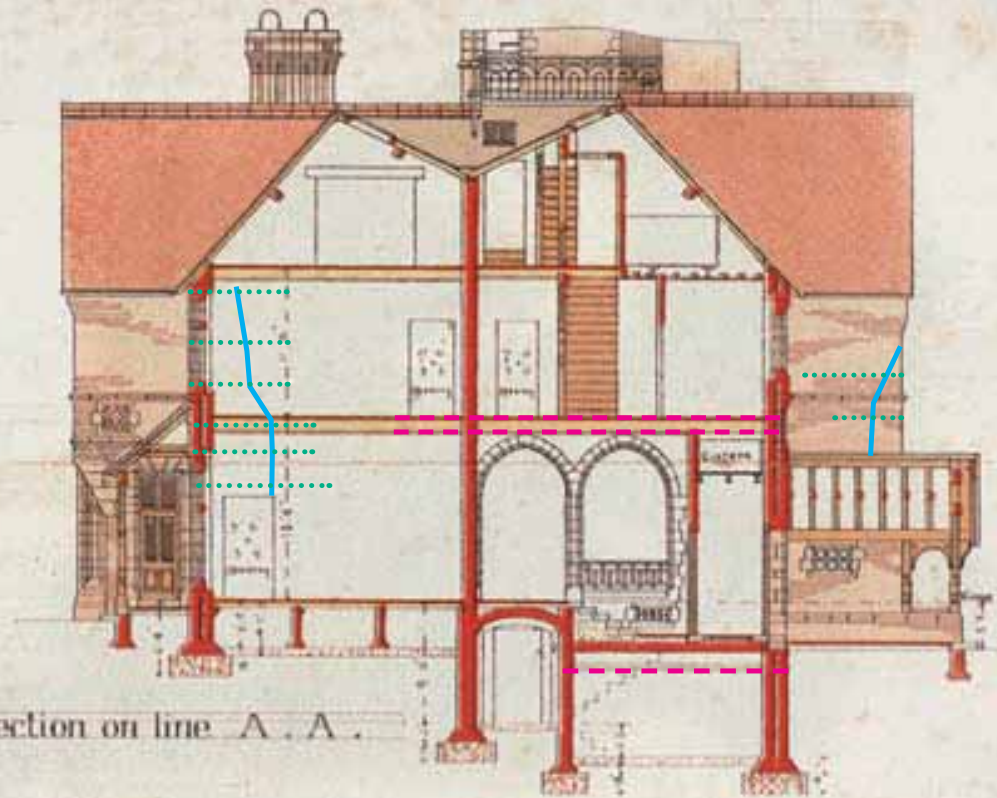

## Arch Failure

**Problem:** Failure of arch with separation & displacement of Voussoirs due to historical foundation movement and / or lateral movement of the adjacent walls.

**Solution:** Radial and lateral stitching through arch construction and jambs of opening to transfer load on arch to stable masonry at level above supported stonework and to secure arch stones. Horizontal Cintec Wall Support Anchors (WSA) located from external wall above arch to transfer load beyond arches and act as a wall support.

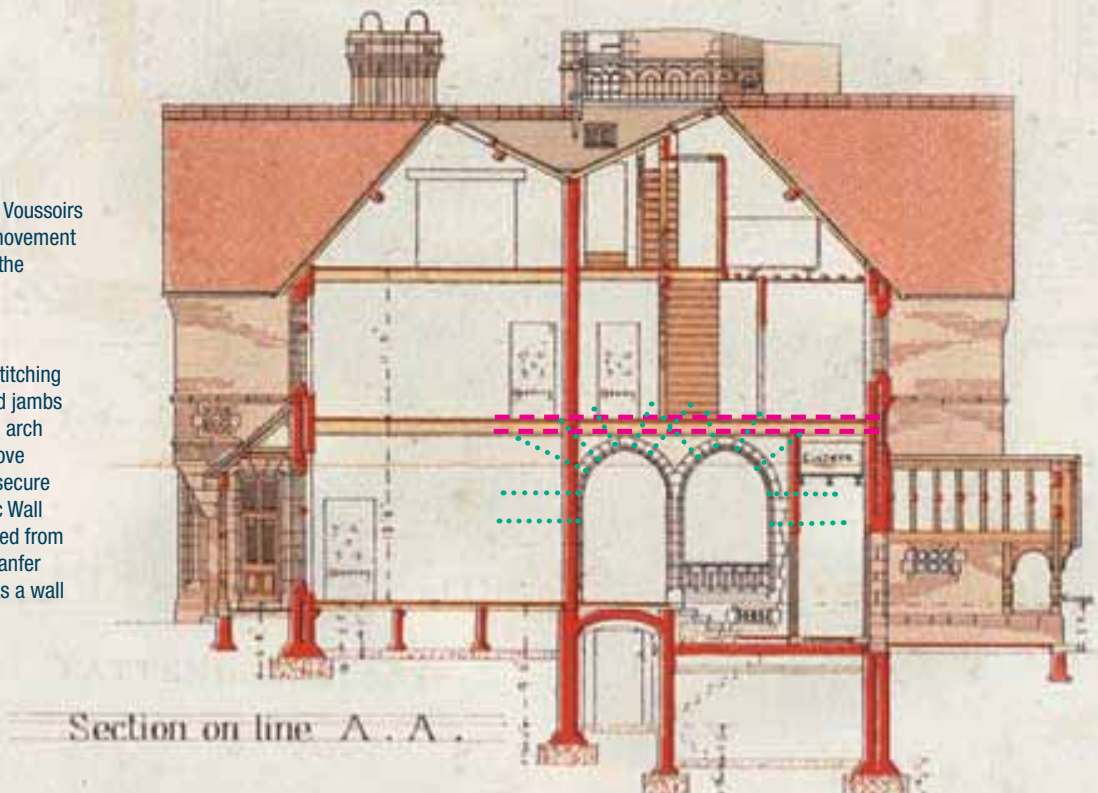



## General Stitching

**Problem:** Bay window vertically separating at angles due to forces exerted by untied trusses to roof turret.

**Solution:** Circumferential stitching with Cintec anchors to create "ring beam" around bay at regular vertical intervals to resist forces of roof load.

**Problem:** Tower vertically separating, lacking in lateral restraint and/or rotation of foundations.

**Solution:** Cintec stitching anchors to entire length of affected walls plus lateral restraint anchors.

**Problem:** Delamination of skins of rubble walls to tower due to thick rubble wall and lack of cross bonding between skins.

**Solution:** Insertion of Cintec Consolidation anchors through bed joints from outside of tower to tie leaves of wall together.

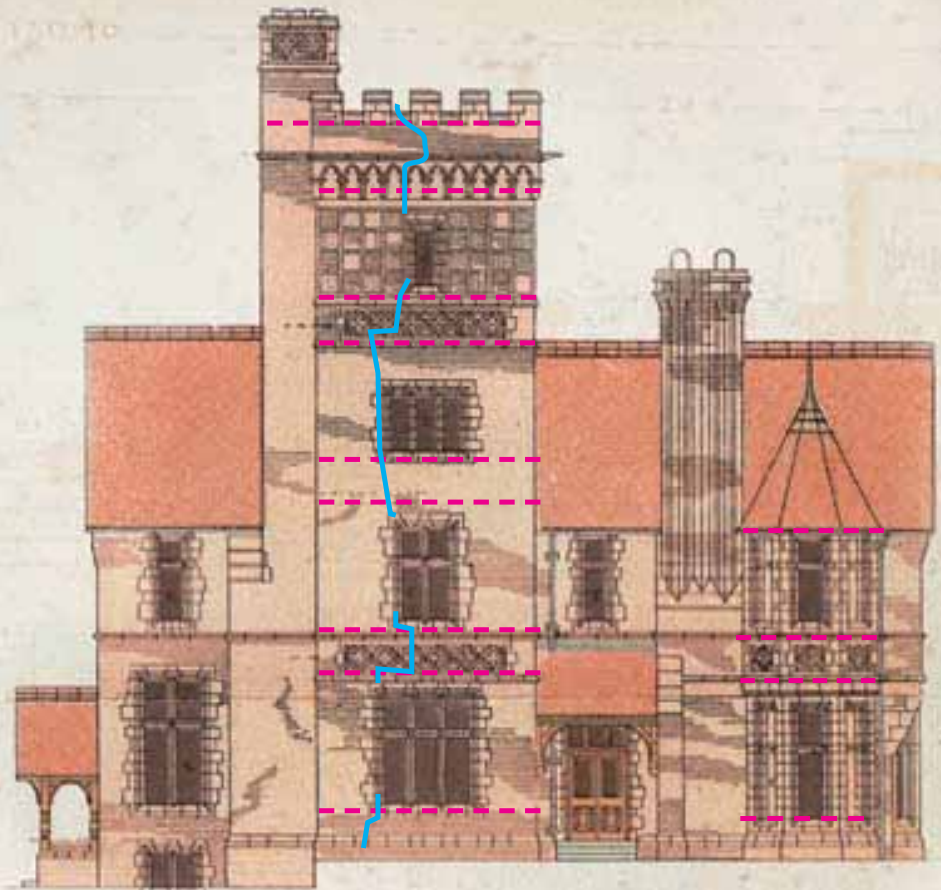

Elevation to the West :

## Chimney Stabilisation

**Problem:** expansion / contraction of stonework to chimney (thermal) causing vertical and horizontal cracking to slender chimney structure.

**Solution:** Vertically placed Cintec anchors including post tensioning to plinth and horizontal banding anchors to secure vertical separation.

**Problem:** Separation of attached chimney from main tower due to lack of bonding and wind loading forces.

**Solution:** Cintec stitching anchors through chimney walls into main walls of tower.

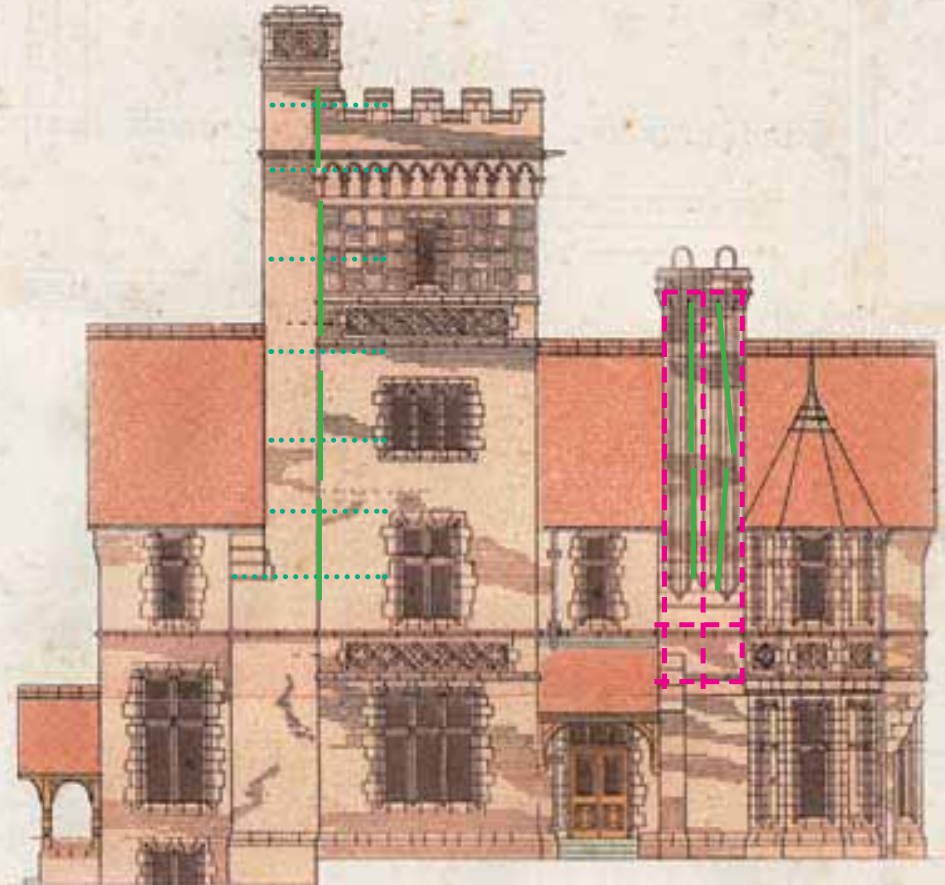

Elevation to the West :

# Anchor Principles

## RAC for Hollow Pot/Brick Cavity Wall

30-80mm sock expansion for hollow pot void NB. Sock diameter can be varied to suit applications

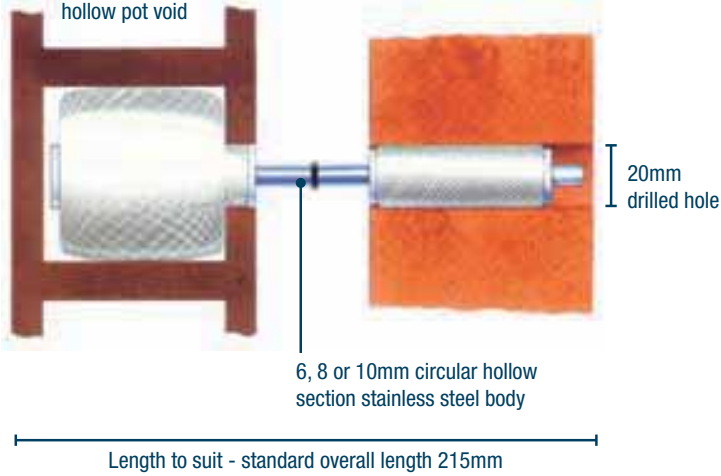

## Stitching Anchor - Type CHS

Sock expands into the soft friable core

Anchor body design dependent on load but normally:

CHS 10 & 18  
SHS 15, 20

Number and position dependent on structural condition



## 'I' Beam Securements to Masonry Facades

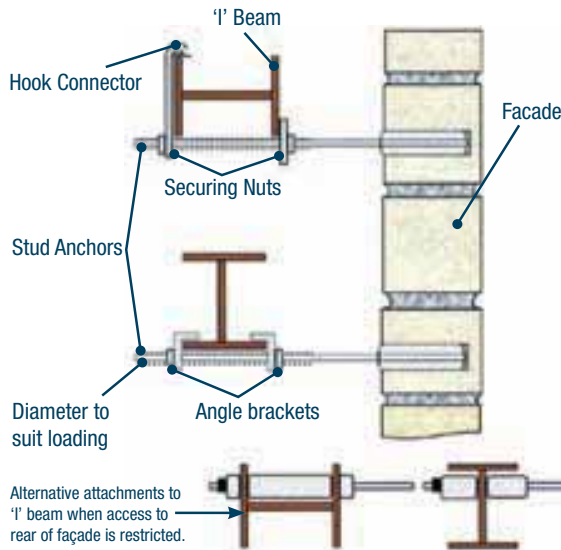

## Retaining Wall/Ground Anchoring

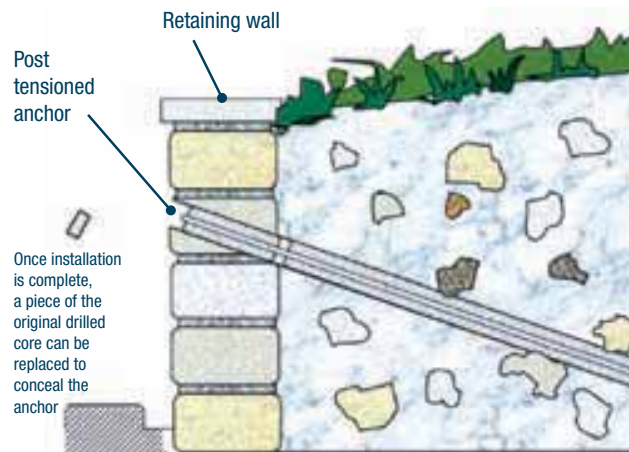

## Stitching Anchor Application - Type CHS

Anchor positioned to suit individual wall conditions

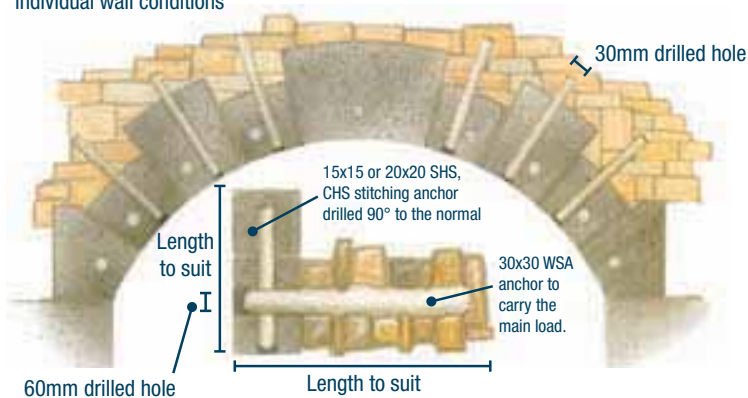

## Terra-Cotta - Typical Detail

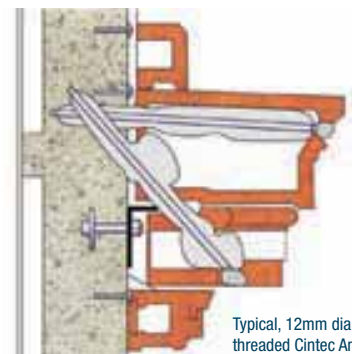



## Features & Benefits

- Designed to the requirements of each application
- Quickly installed
- Aged tested for durability
- Fire resistant
- Cementitious and therefore sympathetic to the original structure
- Controlled grout flow and containment
- Invisible when installed
- Equally effective for structural repairs, ground anchoring parapet walls and masonry arch strengthening

UNITED KINGDOM

**CINTEC INTERNATIONAL LTD**  
 11 Gold Tops, Newport,  
 South Wales NP20 4PH  
 Tel: +44 (0) 1633 246614  
 Fax: +44 (0) 1633 246110  
 Email: [hqcintec@cintec.co.uk](mailto:hqcintec@cintec.co.uk)

CANADA

**CINTEC CANADA LTD**  
 38 Auriga Drive, Suite 200,  
 Nepean, Ontario, Canada K2E 8A5  
 Tel: (1) 613 225 3381  
 Fax: (1) 613 224 9042  
 Email: [solutions@cintec.com](mailto:solutions@cintec.com)

USA

**CINTEC AMERICA INC**  
 510 McCormick Drive, Suite Q,  
 Glen Burnie, MD 21061  
 Tel (1) 800 363 6066  
 Fax (1) 800 461 1862  
 Email: [solutions@cintec.com](mailto:solutions@cintec.com)

AUSTRALIA

**CINTEC AUSTRALASIA PTY LTD**  
 40 Tyrrell Street, PO Box 141,  
 Newcastle, NSW 2300, Australia  
 Tel: +61 (0) 2 49 294841  
 Fax: +61 (0) 2 49 297933  
 Email: [cintec@cintec.com.au](mailto:cintec@cintec.com.au)

INDIA

**CINTEC**  
 1003 Tolstoy House  
 15 - 17 Tolstoy Mar G  
 Connaught Place, New Delhi - 1 India  
 Telephone: +91 (11)6630 5800-03-03  
 Facsimile: +91 (11)6630 5801  
 e-mail: [solutions@cintecindia.com](mailto:solutions@cintecindia.com)

